



**CHRIS
MONTAGUE**
CARBURETTOR CO.

The Centre
for Carburetors
Established in 1965

“When you find you can't get it else you'll probably finish up at Chris M

And it's easy to see why. We actually keep on our shelves most of the carburetters which other dealers order up after you're off the 'phone. We are official Dealers for practically all carburetter manufacturers, and keep most current models in stock—and a good many obsolete ones, too! And we make a special point of keeping lots of spares for all makes as well, because we think it's pretty silly to be the country's premier carburetter dealer if we can't normally help a customer out of trouble for want of a few needles or jets.

But being probably the only carburetter specialists in the land with a German Solex for a BMW 2002 on the shelf—which we can have on your doorstep in Abingdon or Aberdeen by this time tomorrow—is not the only way we can help to keep you or your customer mobile. There's a lot more

to selling carburetters than just stock. We must make sure we're constantly changing specifications. This knowledge, together with our experience, for future reference, gives our customers the best service. We are experienced dealers and we have the relevant, factual information at our quarter of a century's hand.

So don't get grounded by a carburetter problem—come to the specialists. We have the know-how and the spares to get it right for you.

WEBER

Weber carburetters first came to prominence in the U.K. in the early 'sixties when they were fitted as original

equipment on the Fiat 1500 and Cortina 1500 GT. The company's rapid growth resulted both from Ford Motor Company fitting Webers to other cars within the Ford range and from Weber's own spectacular success in motor sport. Today, Weber produce conversion kits for most popular cars—Alfa, Audi, BMW, Ford, Lada, Nissan, Opel, Peugeot, Fiat, Renault, Toyota, Vauxhall, VW and others—to replace the original carburetter. This is often a popular alternative when the original unit has proved troublesome or is expensive to replace. A Weber conversion is usually an economical option in terms of installation, performance and, of course, unparalleled reliability.

Original equipment on: Aston-Martin (pre-injection), some BL, most Ford, Fiat, early Lotus, Peugeot, Renault, Volvo, etc.

Weber Performance Conversions

As a result of our extensive knowledge gained from a motor sporting background in the '60s and '70s, our many Weber performance conversions, including multi-carburetter configurations, for enthusiasts' road cars as well as historic and race/rally cars, are constantly in demand. We have the personal experience and special data to tackle any such carburetter requirement.

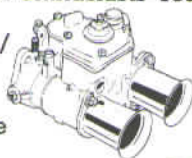

Chris Montague Carburetter Company is one of the original Distributors appointed by Weber and indeed is one of the only remaining names from Weber's list of dealers of those early days. We maintain a very comprehensive stock of these fine carburetters and proudly claim to hold the largest volume of spares in the country.

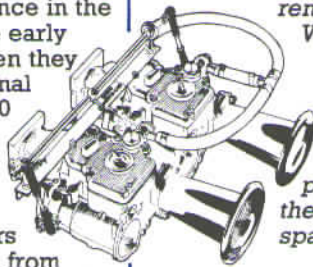

DELLORTO

An Italian carburetter, similar in appearance to certain Webers, and sometimes used as an alternative. Often selected for engine conversions and for competition use.

Original equipment on: Alfa Romeo, Fiat, Lancia, Lotus, Chrysler.

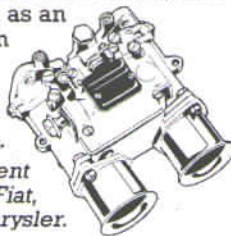

S.U.

Popularly used as performance and economy conversions before Weber's dominance in this field, and still offered as such today. The S.U. is one of the simpler carburetters in both construction and operation, though models introduced in the early '80s became more complex. All parts are readily available and we maintain a wide selection of metering needles.

Original equipment on: Austin, Morris, MG, Rover, Triumph, Jaguar (pre-injection) and other Leyland (now BL) vehicles—Hillman, Avenger, etc., Aston-Martin, Rolls-Royce and a host of 'specials'.

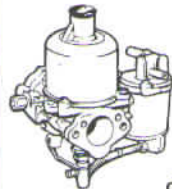

STROMBERG

Similarities in operation and appearance to S.U.

Original equipment on: Chrysler, some GM Vauxhalls, Range Rover, Saab, Triumph, Volvo.

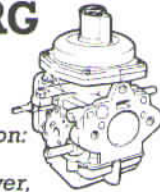

ENGLISH SOLEX / ZENITH

Although the original company is no longer in business, some carburetters and spares are still available.

Original equipment on: early Fords, Chrysler, Hillman, GM (Vauxhall) etc.

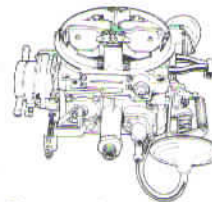

PIERBURG / SOLEX / ZENITH

Increasingly popular choice by some manufacturers as original equipment on English and Continental cars.

Original equipment on: BMW, Fords, Mercedes, Opel, Peugeot, Porsche, Rolls-Royce, late Vauxhalls, Volkos, etc.

Chris Montague Carburetter Company is a Main Dealer for Pierburg/Solex.

TRADE CUSTOMERS, PLEASE NOTE:

Phone us direct for rapid service on replacement carburetters and spares.

NEW AI

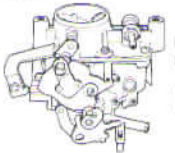

In 1986 Weber Solex (France) appointed Chris Montague Carburetter Co as a Main Dealer.

Solex (France) carburetters for built in France Spain which account for a large proportion on our roads.

Original equipment on: Fiat Lancia, Peugeot, Talbot, etc.

RECON SE

We operate a service for a carburetter models which become obsolete. We offer a service repair price alternative unit and maintenance working to a Please ask for Some recon are available from stock.

where, Montague's''

in just shifting boxes.
e up to date with the
ifications and assimilate
with our own personal
erence. As a result, we avoid
glib jargon handed out by less
instead provide intelligent,
on, gained from nearly a
d-won experience.

by a carburetter
specialists who
the hardware

POINTMENT!

**OLEX
FRANCE)**

ook over
nd
Montague
npany as

roduces
many cars
Italy and
ount for a
a of the cars

ent on:
geot, Renault,

**ITIONING
VICE**

reconditioning
most ANY
cluding those
have now
lete. This
sents a low-
ve to a new
help if you are
ight budget.
fuller details.
tioned units
on exchange

- Biggest stockholding of carburetters and spares available in the U.K.
- All major manufacturers represented
- New and reconditioned carburetters
- Comprehensive data on competition and specialised applications
- Helpful and intelligent answers to your queries
- Very rapid delivery service



**CHRIS
MONTAGUE**
CARBURETTERS

WEBER
CARBURETORS

WEBER
CARBURATORI

WEBER
CARBURATORI

WEBER
CARBURATORI

WEBER

WEBER

WEBER

SPARES FOR ALL CARBURETTORS

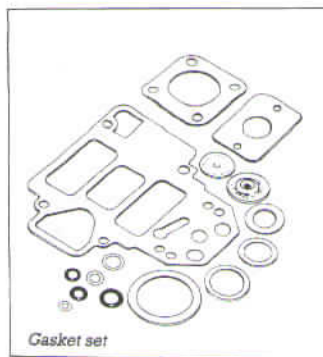

Gasket set

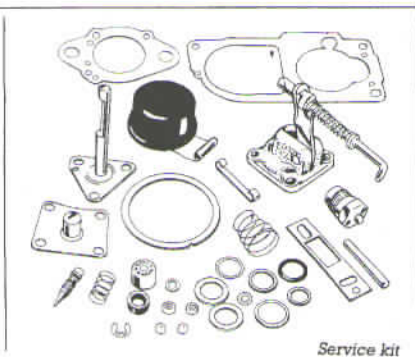

Service kit

SERVICE SPARES

Gasket sets

Whenever a carburettor is dismantled it is necessary to reassemble it with a set of new gaskets to ensure a perfect seal. We keep gasket sets for all carburettor makes and models on the shelf. (There are, however, some instances where these may only be available with a full service repair kit.)

Service Kits

All carburettors should receive regular maintenance in accordance with the manufacturer's recommendations and at such a time you will need the correct service kit. This will include a gasket set and, typically, needle valve, mixture screws, diaphragms, springs etc., to restore a serviceable carburettor to its maximum

capabilities. Remember though, a carburettor is a precision instrument and servicing it is often best handled by a specialist.

NOTE: A service kit is for maintaining a carburettor in peak condition throughout its useful lifetime. **IT WILL NOT CURE A WORN-OUT CARBURETTOR!**

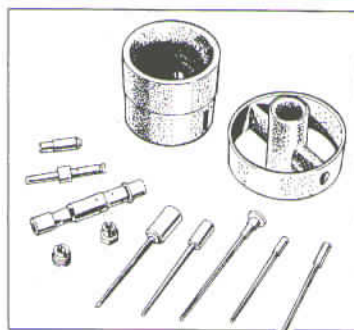

TUNING SPARES

Certain spares will be needed for setting up the carburettor/s if you are

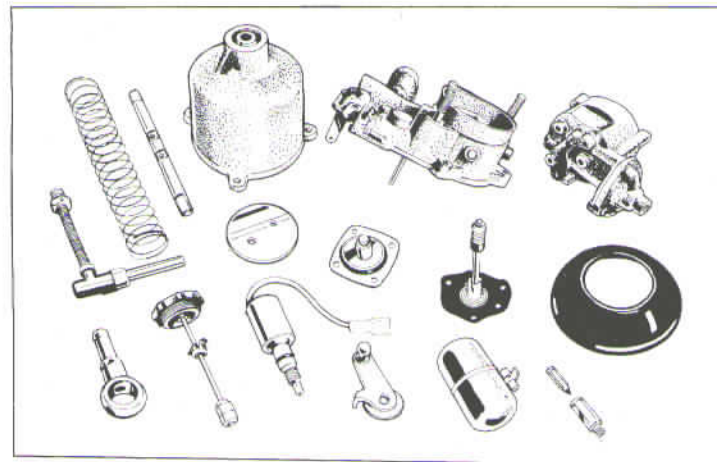

REPLACEMENT PARTS

Often individual carburettor components need to be replaced independently of the rest of the unit, for example in the event of a lost or broken top cover casting, auto-choke mechanism, dashpot or

piston etc. Such parts can normally be obtained separately, from ourselves, as can some of the individual items in the service kits like diaphragms, needle valves, floats, etc.

building a competition car or are carrying out an engine conversion, or sometimes even if you have simply removed or exchanged the air filter system. This will usually involve either a Weber, Dellorto or S.U. carburettor and such spares would typically be main jets, air corrector jets, emulsion tubes, pump jets, idle jets, and choke tubes in the case of Webers or Dellortos, or needles if you are using S.U.s.

We also stock an extensive selection of air trumpets which may well prove necessary to help correct the setting if air filters have been removed.

Please bear in mind that we have extensive personal knowledge, experience and data regarding setting up carburettors on competition or road-tuned engines and if you can leave your car with us for a few days we will normally be able to trace even the most elusive problems.



IMMEDIATE RESPONSE TO YOUR ORDERS

We'll take your order over the phone and deal with it right away. Normally goods are sent out on the day they are ordered via the post or Datapost, or via 24-hour Securicor service (same day despatch of orders received in time for collection at noon), according to customers' preferences. There are also our own Minivans, of course, and, if you're in a real jam, and outside our normal delivery area, we can always use a courier service for same-day delivery.



We are sited near the junction of the Hendon Way (A41) with the Finchley Road, near the Tower Garage (Esso station), 1/4 miles north of Finchley Road Underground (Metropolitan & Jubilee lines) & 3/4 mile south of Golders Green Underground (Northern line).

Suppliers to the Garage and Retail Trade.



FAST MAIL ORDER!

Remember, most spares can be sent 1st class letter-post the same day we receive your order. (Account holders / Access / Visa / Diners Club / Amex cardholders.)

CHRIS MONTAGUE CARBURETTOR CO.

Chris Montague Carburettor Co.
Distributors of Specialised Motor Components & Accessories
380-382 Finchley Road, London NW2 2HP
Telephone: 01-794 7766/7
Telex: 295441 Fax: 01-209 1231